



# UL 458

## STANDARD FOR SAFETY

Power Converters/Inverters and Power Converter/Inverter Systems for Land Vehicles and Marine Crafts

ULNORM.COM : Click to view the full PDF of UL 458 2021

[ULNORM.COM](https://ULNORM.COM) : Click to view the full PDF of UL 458 2021

UL Standard for Safety for Power Converters/Inverters and Power Converter/Inverter Systems for Land Vehicles and Marine Crafts, UL 458

Sixth Edition, Dated September 2, 2015

### **Summary of Topics**

***This revision of ANSI/UL 458 dated January 11, 2021 includes the following changes in requirements:***

- ***Revision to polarity color coding; [58.2](#)***
- ***Revision to scope; [1.1](#), [1.2](#), [1.4](#), [1.5](#), [Table 32.1](#), [Table 35.1](#) and [48.2.5](#)***
- ***Revision to production line test conditions; [Table 54.1](#)***
- ***Revision to address charging lithium batteries; [1.3](#), [Section 14A](#), [58.26](#) and [59.5](#)***

Text that has been changed in any manner or impacted by UL's electronic publishing system is marked with a vertical line in the margin.

The new and revised requirements are substantially in accordance with Proposal(s) on this subject dated July 31, 2020 and October 2, 2020.

All rights reserved. No part of this publication may be reproduced, stored in a retrieval system, or transmitted in any form by any means, electronic, mechanical, photocopying, recording, or otherwise without prior permission of UL.

UL provides this Standard "as is" without warranty of any kind, either expressed or implied, including but not limited to, the implied warranties of merchantability or fitness for any purpose.

In no event will UL be liable for any special, incidental, consequential, indirect or similar damages, including loss of profits, lost savings, loss of data, or any other damages arising out of the use of or the inability to use this Standard, even if UL or an authorized UL representative has been advised of the possibility of such damage. In no event shall UL's liability for any damage ever exceed the price paid for this Standard, regardless of the form of the claim.

Users of the electronic versions of UL's Standards for Safety agree to defend, indemnify, and hold UL harmless from and against any loss, expense, liability, damage, claim, or judgment (including reasonable attorney's fees) resulting from any error or deviation introduced while purchaser is storing an electronic Standard on the purchaser's computer system.

No Text on This Page

[ULNORM.COM](http://ULNORM.COM) : Click to view the full PDF of UL 458 2021

**SEPTEMBER 2, 2015**  
(Title Page Reprinted: January 11, 2021)



**ANSI/UL 458-2020**

1

**UL 458**

**Standard for Power Converters/Inverters and Power Converter/Inverter  
Systems for Land Vehicles and Marine Crafts**

The first, second, and third editions were titled Power Converters and Power-Converter Systems for Recreational Vehicles.

First Edition – February, 1977  
Second Edition – May, 1986  
Third Edition – November, 1991  
Fourth Edition – December, 1993  
Fifth Edition – April, 2006

**Sixth Edition**

**September 2, 2015**

This ANSI/UL Standard for Safety consists of the Sixth Edition including revisions through January 11, 2021.

The most recent designation of ANSI/UL 458 as an American National Standard (ANSI) occurred on December 8, 2020. ANSI approval for a standard does not include the Cover Page, Transmittal Pages, and Title Page.

Comments or proposals for revisions on any part of the Standard may be submitted to UL at any time. Proposals should be submitted via a Proposal Request in UL's On-Line Collaborative Standards Development System (CSDS) at <https://csds.ul.com>.

UL's Standards for Safety are copyrighted by UL. Neither a printed nor electronic copy of a Standard should be altered in any way. All of UL's Standards and all copyrights, ownerships, and rights regarding those Standards shall remain the sole and exclusive property of UL.

**COPYRIGHT © 2021 UNDERWRITERS LABORATORIES INC.**

No Text on This Page

[ULNORM.COM](http://ULNORM.COM) : Click to view the full PDF of UL 458 2021

## CONTENTS

### INTRODUCTION

1	Scope .....	7
2	Glossary .....	7
3	Components .....	11
4	Units of Measurement .....	11
5	Undated References .....	11

### PART I – POWER CONVERTERS AND INVERTERS

#### CONSTRUCTION

6	General .....	11
7	Frame and Enclosure .....	11
8	Enclosures Used For Protected Environments .....	14
9	Accessibility of Uninsulated Live Parts, Film-Coated Wire, and Moving Parts .....	14
	9.1 General .....	14
	9.2 User servicing .....	16
	9.3 Serviceman servicing .....	16
10	Assembly .....	17
11	Protection Against Corrosion .....	17
12	Supply Connections .....	17
	12.1 Permanently-connected converters or inverters .....	17
	12.2 Cord connection .....	20
	12.3 Bushings .....	21
13	Low-Voltage DC Connections and Wiring .....	21
	13.1 General .....	21
	13.2 Cigarette lighter inputs .....	23
14	Secondary Circuits .....	23
14A	Batteries .....	24
15	Live Parts .....	25
16	Internal Wiring .....	25
	16.1 General .....	25
	16.2 Tubing .....	25
	16.3 Protection of wiring .....	26
	16.4 Electrical connections .....	26
	16.5 Separation of circuits .....	27
	16.6 Barriers .....	27
17	Insulating Materials .....	28
18	Transformers .....	28
	18.1 General .....	28
	18.2 Coil insulation .....	28
19	Resistors .....	30
20	Switches and Controllers .....	30
21	Overload-Protective Devices .....	31
	21.1 General .....	31
	21.2 Overcurrent-overtemperature protection .....	31
22	Fuses and Fuseholders .....	32
23	Receptacles .....	33
24	Inverter Output Circuits .....	33
25	Lampholders .....	33
26	Capacitors .....	33

27	Transient Voltage Surge Suppressors .....	34
28	Printed Wiring .....	34
29	Spacings .....	34
	29.1 General.....	34
	29.2 Insulation barriers .....	37
30	Grounding .....	38
31	Bonding of Internal Parts.....	39
	31.1 General.....	39
	31.2 Bonding conductor.....	40

## PERFORMANCE

32	General .....	40
33	Leakage Current Test .....	41
34	Power Input Test .....	43
35	Output Voltage Measurement Test.....	43
36	Capacitor Voltage Measurement Test.....	44
37	Output Voltage and Current Test.....	44
38	Temperature Test .....	44
	38.1 Normal.....	44
	38.2 Maximum output without fan operation .....	48
	38.3 Zero clearance .....	48
	38.4 Maximum overload without trip.....	49
39	External Surface Temperature Limits Test .....	49
40	Dielectric Voltage-Withstand Test .....	50
41	Induced Potential Test .....	50
42	Testing on Transformer Insulating Materials.....	51
43	Strain Relief Test.....	51
44	Overload Test.....	51
45	Overcurrent Protection Calibration Test.....	51
46	Ground-Fault Circuit-Interrupter Evaluation Test For Power Units.....	52
47	Battery Charger Overcharge Test .....	52
48	Abnormal Operation Test .....	53
	48.1 General.....	53
	48.2 Output short-circuit .....	54
	48.3 Switch position .....	55
	48.4 Component malfunction .....	55
	48.5 Rectifier and capacitor short-circuit test .....	55
	48.6 Vibration test .....	55
	48.7 Surge protectors .....	56
	48.8 Specific value overload .....	56
	48.9 Blanketing test.....	56
	48.10 Flanged bobbin transformer abnormal test.....	57
	48.11 Blocked fan .....	58
49	Evaluation of Reduced Spacings on Printed Wiring Boards.....	58
	49.1 General.....	58
	49.2 Dielectric voltage-withstand test.....	59
	49.3 Shorted trace test .....	59
50	Burnout Test .....	59
	50.1 General.....	59
	50.2 Relay and solenoid burnout .....	59
	50.3 Transformer burnout .....	59
51	Gasket Tests .....	60
52	Atomized Water Test.....	61
53	Label Adhesion Test .....	62

**MANUFACTURING AND PRODUCTION TESTS**

54	Dielectric Voltage-Withstand Test .....	63
55	Grounding Continuity Test.....	64

**RATING**

56	General .....	64
----	---------------	----

**MARKINGS**

57	Details .....	65
58	Content .....	65

**INSTRUCTIONS**

59	Instruction Manual .....	68
----	--------------------------	----

**PART II – POWER-CONVERTER SYSTEMS**

60	General .....	68
----	---------------	----

**CONSTRUCTION**

61	Frame and Enclosure .....	68
62	Power-Supply Assembly .....	69
63	Supply and Output Connections .....	70
64	Overcurrent Protection.....	71
65	Transfer Switch/Mechanisms .....	71
66	Spacings .....	71

**PERFORMANCE**

67	Temperature Test .....	72
----	------------------------	----

**MARKINGS**

68	Details.....	72
----	--------------	----

**SUPPLEMENT SA – MARINE POWER CONVERTERS/INVERTERS AND POWER CONVERTER/  
INVERTER SYSTEMS****INTRODUCTION**

SA1	Scope .....	75
SA2	Glossary .....	75

**CONSTRUCTION**

SA3	General.....	75
SA4	Frame and Enclosure.....	76
	SA4.1 General.....	76
	SA4.2 Enclosures for open cockpit or weatherdeck mounting .....	76
SA5	Protection Against Corrosion .....	76

SA6	Supply Connections .....	78
SA7	Internal Wiring And Grounding .....	78
SA8	Battery Connections.....	78
SA9	Ignition Protection .....	78
SA10	Receptacles .....	78
SA11	Arcing Parts.....	78
SA12	Electrical Components .....	79

## PERFORMANCE

SA13	General .....	79
SA14	Water Spray Test .....	79
SA15	Drip Test.....	82
SA16	Leakage Current, Insulation Resistance, and Dielectric Voltage-Withstand (Repeated) .....	82
SA17	Salt Spray Corrosion Test .....	82
SA18	Output Voltage Control .....	83
SA19	Electrolyte Conditioning.....	83
SA20	Battery Discharge .....	83
SA21	Vibration .....	83
SA22	Shock .....	84
SA23	Ignition Protection .....	85
SA24	Metallic Coating Thickness .....	85
SA25	Accelerated Aging of Gaskets, Sealing Compounds and Adhesives.....	87
SA26	Label Adhesion.....	88

## MARKINGS

SA27	Details .....	89
------	---------------	----

## INSTRUCTIONS

SA28	Instruction Manual .....	89
SA29	Important Safety Instructions .....	90
SA30	Assembly Instructions .....	93
SA31	Operating Instructions .....	93
SA32	Maintenance Instructions.....	94

## APPENDIX A

Standards for Components .....	95
--------------------------------	----

## INTRODUCTION

### 1 Scope

1.1 These requirements cover fixed and stationary power converters, power-converter systems, and accessories having a rated nominal input of 120, 120/240, or 240 V, alternating current and a nominal output of 60 V or less, direct current. Additionally, a power converter may have a rated nominal input of 12 – 60 V, direct current. These converters are intended for use within land vehicles where not directly exposed to outdoor conditions and are intended to be employed in accordance with the National Electrical Code, NFPA 70.

1.2 These requirements also cover fixed, stationary and portable power inverters and power-inverter systems having a dc input and a 120 or 240 V ac single phase output or up to 600Y/346V three-phase output. These inverters are intended for use within land vehicles where not directly exposed to outdoor conditions and are intended to be employed in accordance with the National Electrical Code, NFPA 70.

1.3 These requirements also cover converters/inverters that are additionally intended to charge batteries. Batteries intended for use with these systems are lead acid batteries or lithium based batteries, and the batteries are intended to comply with applicable battery standards and be provided with protective measures for discharging and charging. These products are not intended to provide protection to these batteries unless specifically included and evaluated as part of a system.

1.4 Power converters supplied by AC circuits covered by Part I of this standard are intended for connection to established 15- and 20-A branch circuits within a recreational vehicle.

1.5 Power-inverters and converters supplied by DC circuits covered by Part I of this standard are intended for connection to a nominal 12 to 60 V dc battery supply.

1.6 Converters and inverters incorporating provisions for the connection of less than three line-voltage branch circuits are investigated under the requirements in Part I of this standard.

1.7 A power-converter or power-inverter system is intended for direct connection to a power-supply assembly. A system for connection of three or less line-voltage branch circuits, not including the main disconnect, may optionally be evaluated in accordance with the requirements in Part II of this standard, or with the applicable requirements for a Class CTL panelboard in the Standard for Panelboards, UL 67. Power converter systems and power inverter systems also employ circuitry as described in [1.4](#) and [1.5](#).

1.8 A power-converter or power-inverter system provided with more than three line-voltage branch circuits, not including the main disconnect, is investigated to the applicable requirements for a Class CTL panelboard in the Standard for Panelboards, UL 67.

1.9 Converters and inverters incorporating provisions for the connection of more than three line-voltage branch circuits are judged under the requirements in Part I of this standard and the applicable requirements for a Class CTL panelboard in accordance with the Standard for Panelboards, UL 67.

1.10 Each pole of a multiple-pole circuit breaker is a separate circuit.

### 2 Glossary

2.1 For the purpose of this standard the following definitions apply.

2.2 ACCESSIBLE PART – A part located so that it can be contacted by a person, either directly or by means of a probe or tool during user servicing, or that is not recessed the required distance behind an opening.

2.3 BARRIER – A partition for the insulation or isolation of electric circuits, for the isolation of electric arcs, or for isolation of moving parts or hot surfaces. In this respect, a barrier may serve as a portion of an enclosure or as a functional part.

2.4 BRANCH CIRCUIT – That portion of the wiring system beyond the final overcurrent protecting device on the power-distribution panel protecting the circuit to the output.

2.5 CIGARETTE LIGHTER CONNECTOR – The male connector provided as part of a vehicle battery adapter for insertion into a cigarette lighter receptacle or a power outlet.

2.6 CLASS 2 TRANSFORMER – A step-down, isolation type transformer having a secondary voltage of not more than 30 Vrms (42.4 peak) under any condition of loading including open circuit and complying with the applicable requirements in the Standard for Low Voltage Transformers – Part 1: General Requirements, UL 5085-1 and the Standard for Low Voltage Transformers – Part 3: Class 2 and Class 3 Transformers, UL 5085-3.

2.7 CONTROL CIRCUIT – A circuit that carries electric signals directing the performance of a controller that, in turn, governs power delivered to a motor or other load in the equipment. A control circuit does not carry main power current.

2.8 ENCLOSURE – That portion of a unit that reduces the accessibility and unintentional contact of a part that may involve a risk of fire, electric shock or injury to persons, or reduces the risk of propagation of flame, sparks, and molten metal initiated by an electrical disturbance occurring within.

2.9 FIELD-WIRING LEAD – Any lead to which a supply, load or other wire is intended to be connected by an installer.

2.10 FIELD-WIRING TERMINAL – Any terminal to which a supply or other wire is intended to be connected by an installer in the field is a field-wiring terminal unless the wire is provided as part of the product and a pressure terminal, connector, soldering lug, soldered loop, crimped eyelet, or other means for making the connection is factory-assembled to the wire.

2.11 FIXED UNIT – A unit that is intended to be permanently connected electrically.

2.12 FLUSH-WALL-MOUNTED UNITS – Units that are intended to be recessed in a wall.

2.13 LIMITED-ENERGY CIRCUIT – A circuit having a voltage not exceeding 1000 V and the energy limited to 100 VA by a secondary winding of a transformer, or a fixed impedance.

2.14 LIVE PART – Denotes metal or conductive parts that, during intended use, have a potential difference with respect to ground or any other conductive part.

2.15 LOW-VOLTAGE, LIMITED ENERGY CIRCUIT – A circuit involving an alternating voltage of not more than 30 Vrms (42.4 Vpeak) or a direct voltage of not more than 60 V and supplied by:

- a) An inherently limiting Class 2 transformer;
- b) A non-inherently limiting Class 2 transformer and an overcurrent protective device that is:
  - 1) Not of the automatic reclosing type;
  - 2) Trip-free from the reclosing mechanism; and
  - 3) Not readily interchangeable with a device of a different rating;

- c) A combination of an isolated transformer secondary winding and a fixed impedance that complies with all the performance requirements for an energy-limiting Class 2 transformer or power source;
- d) A dry-cell battery that is isolated from the primary circuit and having output characteristics no greater than those of an energy-limiting Class 2 transformer or power source; or
- e) A combination of a rechargeable battery and a fixed impedance that complies with all of the performance requirements for an energy-limiting Class 2 transformer or power source.

2.16 PORTABLE POWER INVERTER – A power inverter that has no provisions for permanent mounting or wiring, and can be easily carried or conveyed by hand.

2.17 POWER-CONVERTER OR POWER-INVERTER SYSTEM – An integral combination of a converter or inverter, power-supply assembly, branch-circuit breakers, grounding bar, marking, and the like, that are necessary for a complete installation.

2.18 POWER SUPPLY ASSEMBLY – Conductors, including grounding conductors insulated from each other, connectors, attachment plugs, and all other fittings, grommets, or devices installed for the purpose of delivering energy from a source of supply to a power-converter or inverter system of a land vehicle or marine craft.

2.19 PRESSURE TERMINAL CONNECTOR – A field wiring terminal that accomplishes the connection of one or more conductors by means of pressure without the use of solder. A pressure terminal connector may be the barrel and set screw type, crimp type barrel, or clamping plate and screw type.

2.20 PRIMARY CIRCUIT – Wiring and components that are conductively connected to a branch circuit or an alternating-current motor generator set installed separately from, or included as, a part of a power-converter or power-inverter system.

2.21 PRINTED WIRING BOARD – The finished combination of a pattern of conductive paths either on, in, or both on and in (multilayer) a sheet of insulating material, including printed components, and the base material.

2.22 PROTECTED ENVIRONMENT – Areas internal to the equipment that are resistant to entry of carbon dust, or other conductive contaminants, and the like.

2.23 PROTECTED ENVIRONMENT ENCLOSURE – A part or total enclosure of an appliance that is constructed as defined in Section 8, Enclosures Used for Protected Environments, so as to maintain a protected environment.

2.24 RISK OF ELECTRICAL ENERGY – HIGH CURRENT LEVELS – The capability for damage to property or injury to persons, other than by electric shock, from available electrical energy is considered to exist, if between a live part and an adjacent dead metal part or between live parts of different polarity, there exists a potential of 2 V or more and either an available continuous power level of 240 VA or more, or a reactive energy level of 20 J or more. For example, a tool, or other metal short circuiting a component may cause a burn or a fire if enough energy is available at the component to vaporize, melt, or more than warm the metal.

2.25 RISK OF ELECTRIC SHOCK – A risk of electric shock is considered to exist at any part if the potential between the part and earth ground or any other accessible part is greater than 42.4 V<sub>peak ac</sub> or 60 V<sub>dc</sub>, and the continuous current flow through a 1500 Ω resistor connected across the potential exceeds 5 mA.

2.26 RISK OF FIRE – A risk of fire is considered to exist at any component unless an investigation of the supply delivering power to that component complies with the criteria in Section 7, Frame and Enclosure.

2.27 RISK OF INJURY TO PERSONS – A condition that exists when stationary parts (such as sharp metal edges and projections), moving parts (such as gears, chains, or linkages), falling objects, inadequate mechanical strength of material, or the physical instability of the equipment are such that injury to persons may result.

2.28 SAFETY CIRCUIT – Any primary or secondary circuit that is relied upon to reduce the risk of fire, electric shock, injury to persons, or electrical energy – high current levels. For example, in some applications, an interlock circuit is considered to be a safety circuit.

2.29 SECONDARY CIRCUIT – A circuit conductively connected to the secondary winding of an isolating power supply transformer.

2.30 SERVICE PERSONNEL – Trained persons having familiarity with the construction and operation of the equipment, and the risks involved, who may periodically open an appliance to repair or maintain electrical or mechanical components.

2.31 STAND ALONE UNITS – Units that are intended to be permanently mounted in place but not recessed in the wall.

2.32 STATIONARY UNIT – Cord- and plug-connected units that are not fixed and are not movable. A stationary unit may have provision for attachment in accordance with this standard.

2.33 POWER SUPPLY CORD – A separable cord set or a length of flexible cord or cable, with one end connected to the primary-circuit wiring of the unit and the other end connected to the attachment plug for connection to branch circuit power.

2.34 SWITCH, TRANSFER – An automatic or nonautomatic device for transferring load conductor connections from one power source to another. May be referred to as transfer switch/mechanism.

2.35 TOOL – A screwdriver, coin, key, or any other object that may be used to operate a screw latch, or similar fastening means.

2.36 TRIP – Denotes automatic interruption of the electric circuit to the load.

2.37 UNIT – For the purposes of this standard, a converter, inverter, converter system, or inverter system, unless specified otherwise.

2.38 USER SERVICING – Any form of servicing that can be performed by personnel other than those who are trained to maintain the unit. Some examples of user servicing are:

- a) The installation of accessories by means of attachment plugs and receptacles, or by means of separable connectors.
- b) The replacement of lamps and fuses, or the resetting of circuit breakers located in a user access area unless they are marked to indicate replacement or resetting by qualified personnel only.
- c) The making of routine operating adjustments necessary to adapt the unit for different intended functions.
- d) Routine cleaning.

### 3 Components

3.1 Except as indicated in [3.2](#), a component of a product covered by this standard shall comply with the requirements for that component. See Appendix [A](#) for a list of standards covering components generally used in the products covered by the standard.

3.2 A component is not required to comply with a specific requirement that:

- a) Involves a feature or characteristic not required in the application of the component in the product covered by this standard, or
- b) Is superseded by a requirement in this standard.

3.3 A component shall be used in accordance with its rating established for the intended conditions of use.

3.4 Specific components are incomplete in construction features or restricted in performance capabilities. Such components are intended for use only under limited conditions, such as certain temperatures not exceeding specified limits, and shall be used only under those specific conditions.

### 4 Units of Measurement

4.1 Values stated without parentheses are the requirement. Values in parentheses are explanatory or approximate information.

### 5 Undated References

5.1 Any undated reference to a code or standard appearing in the requirements of this standard shall be interpreted as referring to the latest edition of that code or standard.

## PART I – POWER CONVERTERS AND INVERTERS

### CONSTRUCTION

#### 6 General

6.1 A unit shall employ materials that are acceptable for the intended use.

#### 7 Frame and Enclosure

7.1 A unit shall be so formed and assembled that it will have the strength and rigidity necessary to resist the abuses to which it may be subjected without increasing the risk of fire, electric shock, or injury to persons due to total or partial collapse with resulting reduction of spacings, loosening or displacement of parts, or other serious defects.

7.2 A unit shall be provided with an enclosure acceptable for the intended application that shall house all parts other than the power-supply cord or primary connector and the output leads or terminals that may increase the risk of fire, electric shock, or injury to persons under normal conditions of use.

7.3 A cast- or sheet-metal section of the enclosure shall have a thickness not less than that specified in [Table 7.1](#).

**Table 7.1**  
**Minimum acceptable thicknesses of enclosure metal**

Metal	At small, flat, unreinforced surfaces and at surfaces of a shape or size to ensure adequate mechanical strength,		At surfaces to which a wiring system is to be connected in the field,		At relatively large unreinforced flat surfaces,	
	in	(mm)	in	(mm)	in	(mm)
Die-cast metal	3/64	(1.2)	–		5/64	(2.0)
Cast malleable iron	1/16	(1.6)	–		3/32	(2.4)
Other cast metal	3/32	(2.4)	–		1/8	(3.2)
Uncoated sheet steel	0.026	(0.66)	0.032	(0.81)	0.026	(0.66)
Galvanized sheet steel	0.029	(0.74)	0.034	(0.86)	0.029	(0.74)
Nonferrous sheet metal other than copper	0.036	(0.91)	0.045	(1.14)	0.036	(0.91)
Sheet copper	0.033	(0.84)	0.043	(1.09)	0.033	(0.84)

7.4 A polymeric enclosure or polymeric part of an enclosure shall comply with the requirements in the Standard for Polymeric Materials – Use in Electrical Equipment Evaluations, UL 746C.

*Exception: A polymeric enclosure or polymeric part of an enclosure in accordance with 7.6 need not comply with this requirement.*

7.5 If the dimensional integrity of nonmetallic material employed for a part is depended upon to maintain continuity of a grounding system, the material is to be investigated with respect to:

- a) Dimensional stability;
- b) Mechanical strength; and
- c) Resistance to creeping and distortion at temperatures to which the material may be subjected under conditions of intended use.

The material shall not display a loss of these properties beyond the minimum acceptable level as a result of aging.

7.6 A nonmetallic part (such as a reset knob, a lever, or a button) protruding through a hole in the enclosure, shall be made of a material classed as V-0, V-1, or V-2 in accordance with the Standard for Tests for Flammability of Plastic Materials for Parts in Devices and Appliances, UL 94, if the area of the hole is 0.6 in<sup>2</sup> (387.1 mm<sup>2</sup>) or less. Nonmetallic parts protruding through a hole having an area larger than 0.6 in<sup>2</sup> shall be made of materials that comply with the requirement in 7.4.

*Exception No. 1: A part of a component need not be classed V-0, V-1, or V-2 if it complies with the flammability requirements applicable to the component.*

*Exception No. 2: A part need not be classed V-0, V-1, or V-2 if, when removed, there are no live parts or moving parts accessible to the user as determined by the requirements in Section 9, Accessibility of Uninsulated Live Parts, Film-Coated Wire, and Moving Parts.*

7.7 A conductive coating applied to a nonmetallic surface (such as the inside surface of a cover or an enclosure) shall comply with the applicable requirements in the Standard for Polymeric Materials – Use in Electrical Equipment Evaluations, UL 746C.

*Exception: If flaking or peeling of the coating will not result in a risk of fire or electric shock as a result of a reduction of spacings or the bridging of live parts, then the coating need not comply with UL 746C.*

7.8 Overtemperature and overcurrent protection shall be located within the unit enclosure. See [21.2.1](#) – [21.2.3](#).

*Exception: The operating handle of a circuit breaker, the operating button of a manually-operable protector, the capped portion of an extractor-type fuseholder, or a similar part may project outside the enclosure.*

7.9 A door or cover of an enclosure shall be hinged or attached in an equivalent manner if it provides access to an overload-protective device the normal functioning of which requires renewal, or if it is necessary to open the cover in connection with normal operation of the protective device. A door or cover providing access to a fuseholder shall be tight-fitting and shall be positively held closed.

7.10 A unit shall be provided with means for securely mounting the unit in its intended operating position. Bolts, screws, or other parts used for mounting the unit shall be independent of those used for securing components.

7.11 If an electrical instrument, such as a meter, forms part of the enclosure, the face or the back of the instrument housing, or both together, shall comply with the requirements for an enclosure.

*Exception: An electrical instrument connected in a secondary circuit need not comply with this requirement if damage to or deterioration of the materials of which the housing is made will not result in a risk of electric shock or fire.*

7.12 Material supporting terminals or used as internal electrical insulation of an electrical instrument shall comply with the requirements in Section [17](#), Insulating Materials.

*Exception: An electrical instrument connected in a secondary circuit need not comply with this requirement if damage to or deterioration of the materials will not result in a risk of electric shock or fire.*

7.13 Supporting feet of a unit that form part of the enclosure or are needed for ventilation shall be reliably secured and the resistance to aging, physical properties, and resistance to combustion of the material shall be investigated.

7.14 A compartment or part of an enclosure that will contain field-wiring splices in other than a Class 2 circuit shall not be provided with ventilating openings.

7.15 The enclosure of a unit shall be such as to prevent molten metal, burning insulation, flaming particles, or the like from falling on combustible materials, including the surface upon which the unit is supported. See Section [50](#), Burnout Test.

7.16 If a screen is needed in the bottom of an enclosure to comply with the requirements in [7.18](#) and [7.19](#), it shall be 14 mesh steel with a minimum wire diameter of 0.018 in (0.46 mm) and shall be mechanically secured in position.

7.17 For a unit having holes in the bottom of the enclosure, the requirements in [7.15](#) will necessitate the use of:

- a) Internal wiring insulated with neoprene, thermoplastic, or glass fiber, or an equally fire-retardant material.

b) An individually enclosed fuse, such as an extractor type. Consideration will be given to a fuse enclosed with a transformer winding.

7.18 A component having a magnetic winding or coil, such as a relay or a solenoid, shall be individually and completely enclosed, or subjected to the burnout tests described in [50.1.1](#) and [50.2.1](#).

7.19 Arcing parts of a switch or relay located in an enclosure having ventilating openings in the bottom shall be individually and completely enclosed, or the switch or relay shall be subjected to the arcing overload test described in [50.3.4](#).

## 8 Enclosures Used For Protected Environments

8.1 A protected environment enclosure provided for compliance with [29.1.1](#) shall be constructed so as to protect the internal parts of the appliance against conductive contaminants and shall comply with the Atomized Water Test, Section [52](#).

*Exception: A part that is uniformly coated or completely encapsulated need not be subjected to the Atomized Water Test.*

8.2 A protected environment enclosure may be provided by means of an enclosure that is:

- a) Hermetically sealed;
- b) Provided with gasketed, tight fitting joints and doors or covers;
- c) Welded, sonically welded, solvent cemented, or provided with tongue and groove joints and seams; or
- d) Encapsulated (potted); or
- e) Conformally coated with a compound that complies with the Standard for Polymeric Materials – Use in Electrical Evaluations, UL 746C, and with the intended application.

8.3 All openings used for cords, leads, bushings, connectors, and the like shall be constructed to preclude entry of dust or other contaminants.

8.4 Gaskets intended to provide tight fitting joints, doors, and covers for a protected environment enclosure shall comply with the Gasket Tests, Section [50](#).

8.5 Potting shall be used within its temperature rating. Prior to potting, all parts shall be mechanically secured.

## 9 Accessibility of Uninsulated Live Parts, Film-Coated Wire, and Moving Parts

### 9.1 General

9.1.1 An uninsulated live part, film-coated wire, or moving part, that could result in a risk of electric shock or injury to persons shall be located or enclosed so that unintentional contact is precluded.

9.1.2 An opening in the enclosure of a unit that will not permit entrance of a 3/4-in (19.1-mm) diameter rod is acceptable if a probe as illustrated in [Figure 9.1](#) cannot be made to touch any uninsulated live part, film-coated wire, and moving part, that could result in a risk of electric shock when inserted through the opening.

Figure 9.1  
Accessibility probe

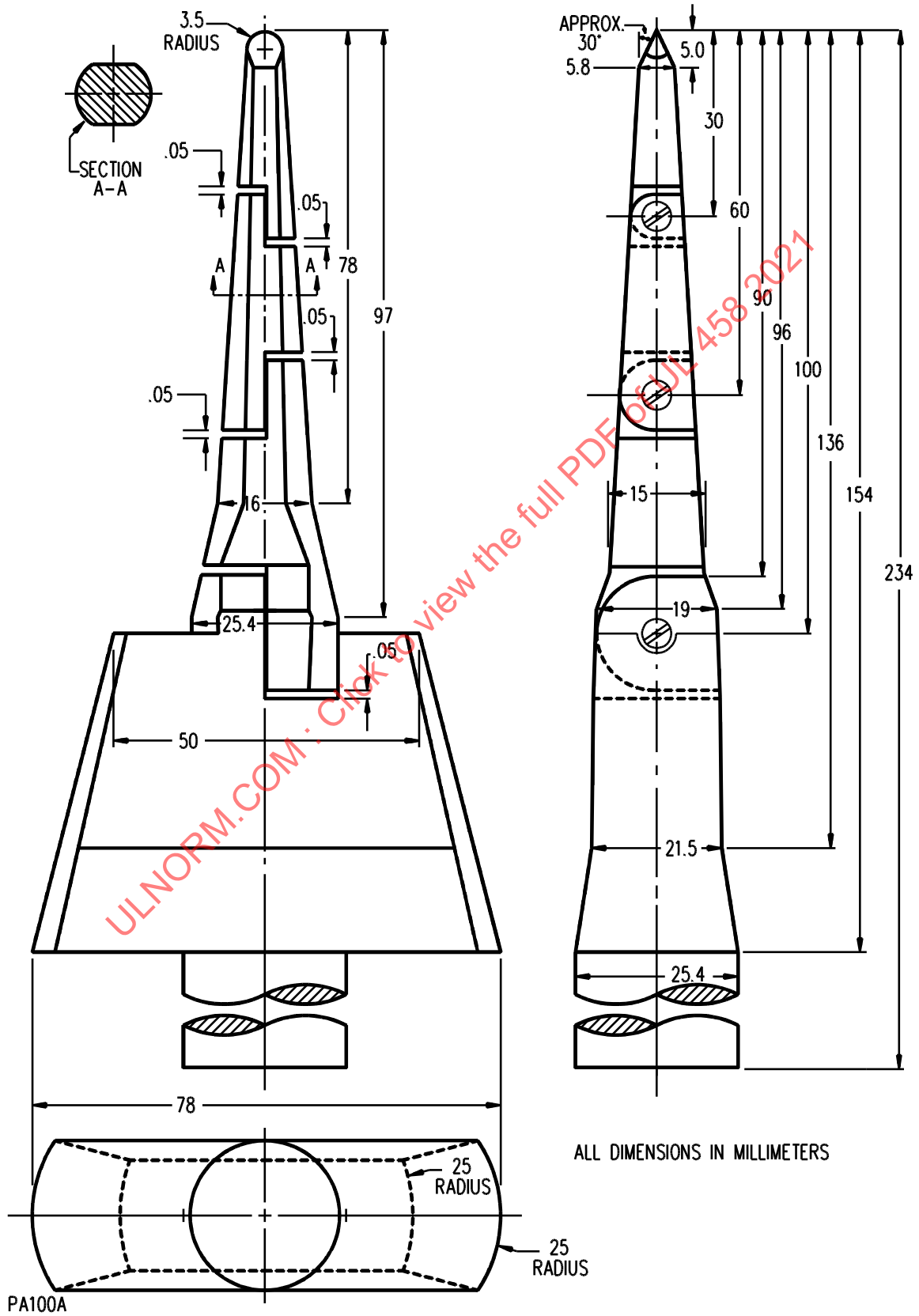

9.1.3 Perforated sheet metal shall not be less than 0.042-in (1.07-mm) thick if the perforations are 1/2 in<sup>2</sup> (3.2 cm<sup>2</sup>) or less in area, and shall not be less than 0.080-in (2.03-mm) thick for larger openings.

*Exception: Perforated sheet metal not less than 0.020-in (0.51-mm) thick may be used where the indentation of a guard or enclosure will not affect the clearance between uninsulated live parts, film-coated wire, or moving parts and grounded metal.*

9.1.4 A door or cover that provides access to a live part, film-coated wire, or moving part, that may result in a risk of electric shock, shall be securely held in place so that it can be opened or removed only by using a tool.

## 9.2 User servicing

9.2.1 Live parts, film-coated wire, and moving parts shall be arranged and covers located so as to reduce the likelihood of a risk of electric shock while covers are being removed and replaced if it is necessary to do so to perform a servicing function as indicated in the operator's instruction manual accompanying the unit.

9.2.2 Live parts, film-coated wire, and moving parts shall be:

- a) Recessed at least 1/8 in (3.2 mm) from the plane of the front of the fixed portion of an enclosure; or
- b) Recessed at least 1/8 in (3.2 mm) from the front edge of a wiring compartment, in the case of a device mounted to the face of a wiring compartment; or
- c) Afforded equivalent protection by projections or guards.

To determine whether such live parts, film-coated wire, and moving parts comply with the requirement in [9.2.1](#), the cover is to be removed and replaced. Contact of either persons or a conductive cover with live parts, film-coated wire, or moving parts is unacceptable.

9.2.3 Operations and adjustments that are considered to subject parts to contact by the user include those made at the time of installation or during normal use, and operations such as relamping, replacing a fuse, and resetting an overload device.

9.2.4 A part on the back of a component mounting panel and a part located so as to require major disassembly by using a tool are not considered to be exposed to the user, and are not considered to be exposed to the serviceman unless it is likely that servicing will be done while the parts are energized after disassembly.

## 9.3 Serviceman servicing

9.3.1 An electrical component that may require adjustment, servicing, or maintenance not specified in the operator's manual shall be located and mounted with respect to other components and with respect to grounded metal parts so that it is accessible for electrical service functions without subjecting the serviceman to the likelihood of electric shock or injury to persons. Access to components for servicing shall not be impeded by other components or by wiring in the direction of access.

9.3.2 The electrical components mentioned in [9.3.1](#) include a fuse and an adjustable control.

9.3.3 All conductive internal parts that are accessible to service personnel and that are usually expected to be at ground potential (heatsinks and the like), but are energized and involve a risk of electric shock, shall be marked in accordance with [58.22](#).