

ISO

INTERNATIONAL ORGANIZATION FOR STANDARDIZATION

ISO RECOMMENDATION

R 382

withdrawn 1980

GYMNASTIC EQUIPMENT

BALANCING BEAM

1st EDITION

December 1964

COPYRIGHT RESERVED

The copyright of ISO Recommendations and ISO Standards belongs to ISO Member Bodies. Reproduction of these documents, in any country, may be authorized therefore only by the national standards organization of that country, being a member of ISO.

For each individual country the only valid standard is the national standard of that country.

Printed in Switzerland

Also issued in French and Russian. Copies to be obtained through the national standards organizations.

BRIEF HISTORY

The ISO Recommendation R 382, *Gymnastic Equipment. Balancing Beam*, was drawn up by Technical Committee ISO/TC 83, *Gymnastics and Sports Equipment*, the Secretariat of which is held by the Deutscher Normenausschuss (DNA).

Work on this question by the Technical Committee began in 1956 and led, in 1961, to the adoption of a Draft ISO Recommendation.

In December 1961, this Draft ISO Recommendation (No. 490) was circulated to all the ISO Member Bodies for enquiry. It was approved, subject to a few modifications of an editorial nature, by the following Member Bodies:

Austria	India	Spain
Bulgaria	Japan	Switzerland
Denmark	Netherlands	Turkey
France	New Zealand	United Kingdom
Germany	Pakistan	U.S.S.R.
Greece	Poland	

No Member Body opposed the approval of the Draft.

The Draft ISO Recommendation was then submitted by correspondence to the ISO Council, which decided, in December 1964, to accept it as an ISO RECOMMENDATION.

GYMNASTIC EQUIPMENT

BALANCING BEAM

FOREWORD

This ISO Recommendation has been elaborated in co-operation with the International Gymnastic Federation (IGF). It concerns gymnastic equipment the use of which is recommended for international competitions.

1. SHAPES AND DIMENSIONS

Shapes and dimensions not specified are left to the discretion of the manufacturer.

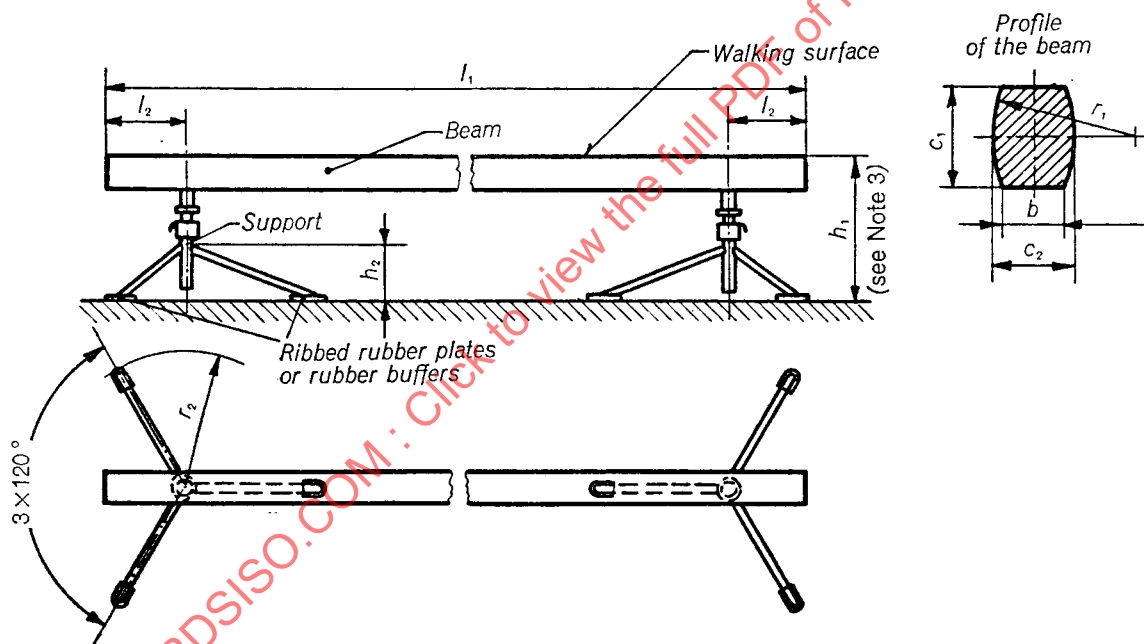

NOTES

1. Material for the walking surface of the beam: wood which resists the risk of splintering, and for the supports: steel or cast iron.
2. The walking surface should be even and have a matt finish; the remainder of the beam should be clear-lacquered.
3. The height h_1 of the beam should be adjustable in steps of not more than 50 mm = 1.968 in (exact corresponding value) or $1 \frac{15}{16}$ in (permissible rounded value).
4. The height adjustment device should be constructed so that the efficiency of the fixture will not be diminished during use.
5. The balancing beam should not vibrate on its supports during use.
6. The arrangement of the fixed feet and adjustable leg should be such as to ensure stability on uneven ground.